

Input Rectifier Diode, 10 A

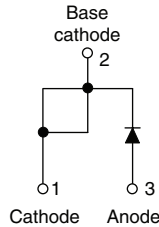

TO-220AC



FEATURES/DESCRIPTION

The 10ETS... rectifier series has been optimized for very low forward voltage drop, with moderate leakage. The glass passivation technology used has reliable operation up to 150 °C junction temperature.

Typical applications are in input rectification and these products are designed to be used with Vishay HPP switches and output rectifiers which are available in identical package outlines.

This product has been designed and qualified for industrial level.

PRODUCT SUMMARY	
V_F at 10 A	< 1 V
I_{FSM}	200 A
V_{RRM}	800 to 1200 V

OUTPUT CURRENT IN TYPICAL APPLICATIONS			
APPLICATIONS	SINGLE-PHASE BRIDGE	THREE-PHASE BRIDGE	UNITS
Capacitive input filter $T_A = 55\text{ °C}$, $T_J = 125\text{ °C}$ common heatsink of 1 °C/W	12.0	16.0	A

MAJOR RATINGS AND CHARACTERISTICS			
SYMBOL	CHARACTERISTICS	VALUES	UNITS
$I_{F(AV)}$	Sinusoidal waveform	10	A
V_{RRM}		800 to 1200	V
I_{FSM}		200	A
V_F	10 A, $T_J = 25\text{ °C}$	1.1	V
T_J		- 40 to 150	°C

VOLTAGE RATINGS			
PART NUMBER	V_{RRM} , MAXIMUM PEAK REVERSE VOLTAGE V	V_{RSM} , MAXIMUM NON-REPETITIVE PEAK REVERSE VOLTAGE V	I_{RRM} AT 150 °C mA
10ETS08	800	900	0.5
10ETS10	1000	1100	
10ETS12	1200	1300	

ABSOLUTE MAXIMUM RATINGS				
PARAMETER	SYMBOL	TEST CONDITIONS	VALUES	UNITS
Maximum average forward current	$I_{F(AV)}$	$T_C = 105\text{ °C}$, 180° conduction half sine wave	10	A
Maximum peak one cycle non-repetitive surge current	I_{FSM}	10 ms sine pulse, rated V_{RRM} applied	170	
		10 ms sine pulse, no voltage reapplied	200	
Maximum I^2t for fusing	I^2t	10 ms sine pulse, rated V_{RRM} applied	130	A ² s
		10 ms sine pulse, no voltage reapplied	145	
Maximum $I^2\sqrt{t}$ for fusing	$I^2\sqrt{t}$	t = 0.1 to 10 ms, no voltage reapplied	1450	A ² √s

10ETS... High Voltage Series



Vishay High Power Products Input Rectifier Diode, 10 A

ELECTRICAL SPECIFICATIONS					
PARAMETER	SYMBOL	TEST CONDITIONS		VALUES	UNITS
Maximum forward voltage drop	V_{FM}	10 A, $T_J = 25\text{ }^\circ\text{C}$		1.1	V
Forward slope resistance	r_t	$T_J = 150\text{ }^\circ\text{C}$		20	$\text{m}\Omega$
Threshold voltage	$V_{F(TO)}$			0.82	V
Maximum reverse leakage current	I_{RM}	$T_J = 25\text{ }^\circ\text{C}$	$V_R = \text{Rated } V_{RRM}$	0.05	mA
		$T_J = 150\text{ }^\circ\text{C}$		0.50	

THERMAL - MECHANICAL SPECIFICATIONS					
PARAMETER	SYMBOL	TEST CONDITIONS		VALUES	UNITS
Maximum junction and storage temperature range	T_J, T_{Stg}			- 40 to 150	$^\circ\text{C}$
Maximum thermal resistance, junction to case	R_{thJC}	DC operation		2.5	$^\circ\text{C/W}$
Maximum thermal resistance, junction to ambient (PCB mount)	$R_{thJA}^{(1)}$			62	
Soldering temperature	T_S			240	$^\circ\text{C}$
Approximate weight				2	g
				0.07	oz.
Marking device		Case style TO-220AC		10ETS08	
				10ETS10	
				10ETS12	

Note

⁽¹⁾ When mounted on 1" square (650 mm²) PCB of FR-4 or G-10 material 4 oz. (140 μm) copper 40 $^\circ\text{C/W}$
 For recommended footprint and soldering techniques refer to application note #AN-994



10ETS... High Voltage Series

Input Rectifier Diode, 10 A Vishay High Power Products

ORDERING INFORMATION TABLE

Device code	10	E	T	S	12	-
	①	②	③	④	⑤	⑥
1	-	Current rating (10 = 10 A)				
2	-	Circuit configuration: E = Single diode				
3	-	Package: T = TO-220AC				
4	-	Type of silicon: S = Standard recovery rectifier				
5	-	Voltage code x 100 = V_{RRM}				
6	-	• None = Standard production • PbF = Lead (Pb)-free				

08 = 800 V
10 = 1000 V
12 = 1200 V

TO-220AC

DIMENSIONS in millimeters and inches

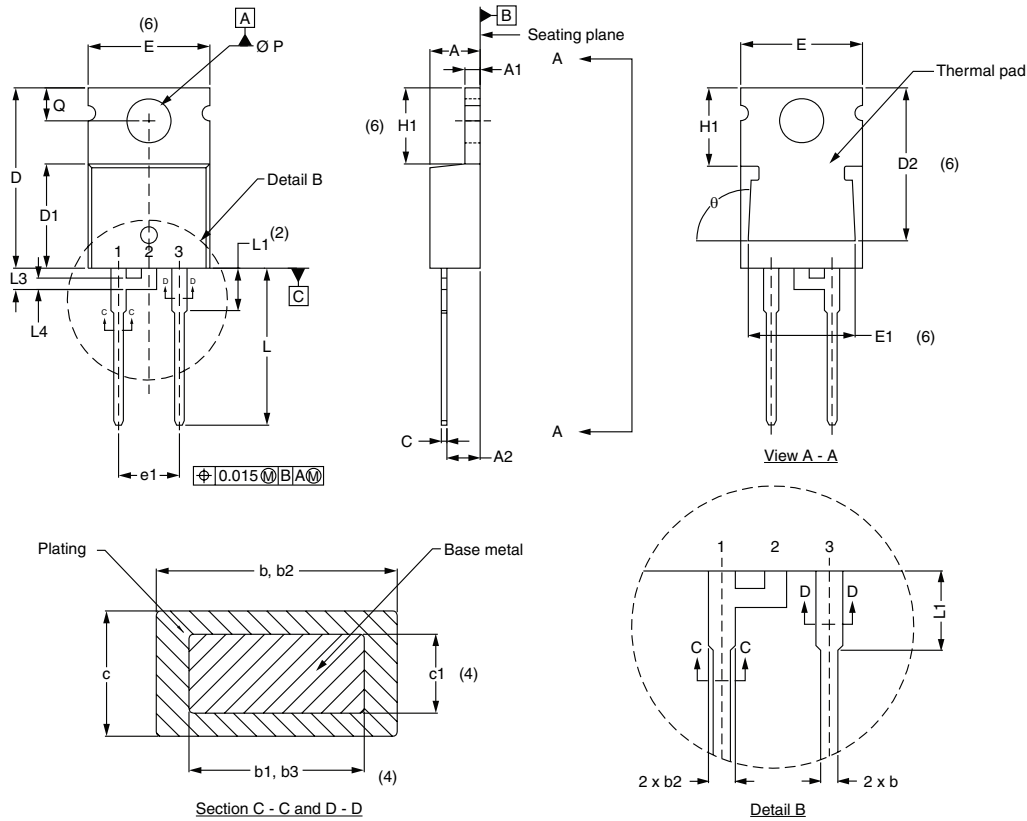

SYMBOL	MILLIMETERS		INCHES		NOTES
	MIN.	MAX.	MIN.	MAX.	
A	3.56	4.82	0.140	0.190	
A1	0.51	1.40	0.020	0.055	
A2	2.04	2.92	0.080	0.115	
b	0.38	1.01	0.015	0.040	
b1	0.38	0.96	0.015	0.038	4
b2	1.15	1.77	0.045	0.070	
b3	1.15	1.73	0.045	0.068	4
c	0.36	0.61	0.014	0.024	
c1	0.36	0.56	0.014	0.022	4
D	14.22	15.87	0.560	0.625	3
D1	8.38	9.02	0.330	0.355	
D2	12.19	12.88	0.480	0.507	6

SYMBOL	MILLIMETERS		INCHES		NOTES
	MIN.	MAX.	MIN.	MAX.	
E	9.66	10.66	0.380	0.420	3, 6
E1	8.38	8.89	0.330	0.350	6
e	2.54 BSC		0.100 BSC		
e1	5.08 BSC		0.200 BSC		
H1	5.85	6.86	0.230	0.270	6
L	12.70	14.73	0.500	0.580	
L1	-	6.35	-	0.250	2
L3	1.78	2.13	0.070	0.084	
L4	0.76	1.27	0.030	0.050	
Ø P	3.54	3.73	0.139	0.147	
Q	2.54	3.05	0.100	0.120	
θ	90° to 93°		90° to 93°		

Notes

- (1) Dimensioning and tolerancing per ASME Y14.5M-1994
- (2) Lead dimension and finish uncontrolled in L1
- (3) Dimension D and E do not include mold flash. Mold flash shall not exceed 0.127 mm (0.005") per side. These dimensions are measured at the outermost extremes of the plastic body
- (4) Dimension b1, b3 and c1 apply to base metal only
- (5) Controlling dimensions: inches
- (6) Thermal pad contour optional within dimensions E, H1, D2 and E1
- (7) Outline conforms are derived from the actual package outline